

SLAMf Series

Thermal Mass Flow



Model SLAMf

Elastomer Sealed, Digital, Thermal Mass Flow Meters and Controllers

Overview

The SLA Series mass flow meters and mass flow controllers have gained broad acceptance as the standard for accuracy, stability and reliability. These products have a wide flow measurement range and are suitable for a broad range of temperature and pressure conditions making them well suited for industrial & academic applications, such as chemical & petrochemical research, laboratory test & experimentation, analytical systems, fuel cell research & development, & life sciences process control, among others.

Highlights of the SLAMf Series mass flow product include: industry leading long term stability, accuracy backed by superior metrology systems and methods using primary calibration systems directly traceable to international standards, and a broad range of analog and digital I/O options to suite virtually any application. An independent diagnostic/service port permits users to troubleshoot or change flow conditions without removing the mass flow controller from service. The SLAMf Series products have NEMA 4X and IP66 weatherproof protection enclosures for 'Hosedown' applications such as; Food, Beverage, Pilot Plants, Pharmaceutical and Biotech.

Product Description

The SLAMf Series provides a highly configurable platform based on a simple modular architecture. The SLAMf Series feature set was carefully selected to enable drop-in replacement and upgrade of many brands of mass flow controllers. With the wide range of options and features available, the SLAMf Series provides users with a single platform to support a broad range of applications.

Features and Benefits

Features	Benefits
Industry leading sensor stability	Increased system throughput and reduced cost of ownership by reducing maintenance and eliminating periodic recipe adjustments and/or device recalibrations
User accessible service port	Simplified installation, start-up, troubleshooting and access to diagnostics provides maximum uptime
Advanced diagnostics	Ensures device is operating within user specified limits for high process yield and maximum uptime
Superior valve technology	Minimum leak-by, maximum turndown, and fast response reduces overall gas panel cost and increases throughput
Adaptable mechanical configurations	Easily retrofit to existing systems
Primary standard calibration systems	Ensures measurement accuracy is traceable to international standards
Simple modular design	Easy-to-service elastomer sealed design provides for factory or field service maximizing uptime and reducing total cost of ownership

Product Description

Advanced Thermal Flow Measurement Sensor

Brooks' sensor technology combines:

- Excellent signal to noise performance for improved accuracy at low setpoints
- Superior long-term stability through enhanced sensor manufacturing and burn in process
- Isothermal packaging to reduce sensitivity to external temperature changes
- Corrosion resistant sensor flow path

Advanced Diagnostics

The mass flow controller remains the most complex and critical component in gas delivery systems. When dealing with highly toxic or corrosive gases, removing the mass flow controller to determine if it is faulty should be the last resort. In response to this, Brooks pioneered smarter mass flow controllers with embedded self test routines and introduced an independent diagnostic/service port to provide the user with a simple interface, for troubleshooting without disturbing flow controller operation.

Wash-down Enclosure

The SLAMf Series comes equipped with an IP66 / NEMA4X rated enclosure. This makes these instruments perfect for wash-down or outdoor environments. So no matter how harsh the surroundings, the SLAMf Series keeps the process under control.

Wide Flow Range

The SLAMf Series covers an extremely broad range of flow rates. Model SLAMf50 can have a full scale flow as low as 3 ccm. With a high turndown ratio of 100:1 for any full scale range from 1-50 lpm N₂ equivalent and 50:1 turndown for all other flow rates, accurate gas flow can be measured or controlled down to 0.06 ccm! Model SLAMf53 can monitor or control gas flows up to 2,500 lpm. Model SLAMf64 can monitor gas flows up to 36,000 lpm.

Fast Response Performance

The all-digital electronics and superior mechanical configuration in the SLAMf Series provide for ultra fast response characteristics.

Broad Array of Communication Options

Brooks offers traditional 0-5 volt and 4-20mA analog options as well as RS485 digital communications ("S-protocol", based on HART). Brooks also offers control interfaces via digital network protocols like DeviceNet, a high speed (up to 500k baud) digital communication network, Profibus and EtherCAT. Brooks' communication capabilities and device-profiles have been certified by the ODVA (Open DeviceNet Vendor's Association) and the ITK (Interoperability Test Kit). Other network protocols are in development. Talk to your Brooks representative about your specific needs.

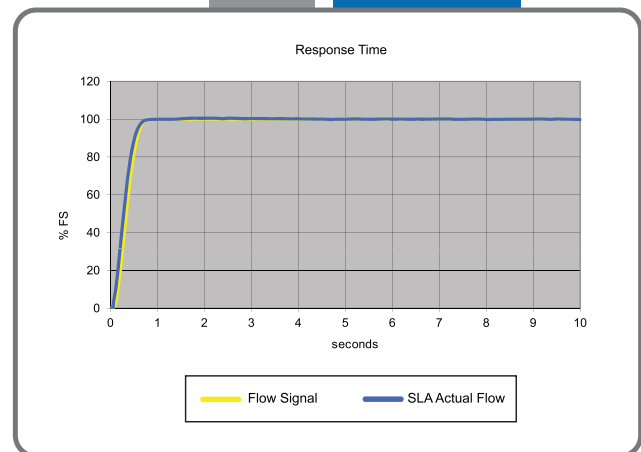

Product Specifications

Flow Ranges and Pressure Ratings:

Mass Flow Controller Model	Mass Flow Meter Model	Flow Ranges N2 Eq. Ratings		Pressure Unit psi/bar		PED Module H Category
		Min. F.S.	Max. F.S.	Standard	Optional	
SLAMf50	SLAMf60	0.003	50 lpm	1500 psi/103 bar	4500 psi/310 bar	SEP
SLAMf51	SLAMf61	15	200 lpm ⁽¹⁾	1500 psi/103 bar ⁽²⁾	NA ⁽³⁾	SEP
SLAMf53	SLAMf63	100	2500 lpm	1000 psi/70 bar	NA	1 for all 150 lb flanges 2 for all other connections
-	SLAMf64	18	2160 m ³ /n	Flow rate dependant		1-1/2" - 100 bar 2" & 3" - 85 bar 4" & 6" - 70 bar 8" - 50 bar

⁽¹⁾ 600 lpm of H2 possible with decreased accuracy ⁽²⁾ 1000 psi/70 bar for UL Certification ⁽³⁾ 4500 psi/310 bar available as a special on the SLAMf61 only
> 40 psig inlet required for flows greater than 100 lpm

Performance

	SLAMf50/60	SLAMf51/61	SLAMf53/63	SLAMf64
Flow Accuracy	±0.9% of S.P. (20-100% F.S.), +0.18% of F.S. (2-20% F.S., 1-20% F.S. from 1-50 lpm)		±0.9% of S.P. (20-100% F.S.), ±0.18% of F.S. (2-20% F.S.) up to 1100 lpm, ±1.0% of F.S. from 1100 lpm up to 2500 lpm	±1% F.S.
Control Range	Turndown 100:1 for F.S. from 1-50 lpm (50:1 for all other F.S. flows)			N/A
Repeatability & Reproducibility	0.20% S.P.			±0.25% S.P.
Linearity	Included in accuracy			
Response Time (Settling Time within ±2% F.S. for 0-100% command step)*	< 1 second		< 3 seconds	N/A
Zero Stability	< ± 0.2% F.S. per year			
Temperature Coefficient	Zero: <0.05% of F.S. per °C. Span: < 0.1% of S.P. per °C			
Pressure Coefficient	±0.03% per psi (0-200 psi N2)			
Attitude Sensitivity	<0.2% F.S. maximum deviation from specified accuracy after re-zeroing			

Ratings

Operating Temperature Range	-14 to 65°C (7 to 149°F)**			
Minimum Pressure Differential (Controllers)	5 psi/0.35 bar	10 psi/0.69 bar	Min.: 11.7 psi/0.81 bar at 500 lpm Min.: 14.5 psi/1.00 bar at 1000 lpm Min.: 35.0 psi/2.41 bar at 2500 lpm	N/A
Maximum Pressure Differential (Controllers)	Application specific up to 1500 psi/103.4 bar	50 psi/3.45 bar	300 psi/20.0 bar	N/A
Leak Integrity (external)	1x10 ⁻⁹ atm. cc/sec He			

Mechanical

Valve Type	Normally Closed, Normally Open, Meter	Meter
Primary Wetted Materials	316L Stainless Steel, High Alloy Stainless Steel, Viton® fluoroelastomers, Buna-N, Kalrez®, Teflon®/Kalrez®, and EPDM	

* Response time can be improved upon request

Diagnostics

Status Lights	MFC Health, Network Status
Alarms*	Sensor Output, Control Valve Output, Over Temperature, Power Surge/Sag, Network Interruption
Diagnostic/Service Port	RS485 via 2.5mm jack (Located under the top cover)

* Alarm modes are dependent on the communications interface. These are described in the corresponding digital communication interface manual.

** Hazardous area certifications have a temperature range limitation of 0-65°C.

Electrical Specifications

Communication Protocol	RS485	Profibus®	DeviceNet™	EtherCAT®
Electrical Connection	All: PG11 Cable Gland, 1/2" NPT (F) Conduit, M20 x 1.5 Conduit DeviceNet Only: 5-Pin Micro Connector			5-Pin M8 Connector
Analog I/O	0-5 V, 1-5 V, 0-10 V, 0-20 mA, 4-20 mA		N/A	0-5 V
Power Max./Purge	From +13.5 Vdc to +27 Vdc		From +11 Vdc to +25 Vdc	From +13.5 Vdc to +27 Vdc
Power Requirements Watts, Max.	Valve Orifice > 0.032": 8 W Valve Orifice ≤ 0.032": 5 W Without Valve: 2 W		Valve Orifice > 0.032": 10 W Valve Orifice ≤ 0.032": 7 W Without Valve: 4 W	Valve Orifice > 0.032": 8.5 W Valve Orifice ≤ 0.032": 5.5 W Without Valve: 2.5 W

Voltage Set Point Input Specifications

Nominal Range	0-5 Vdc, 1-5 Vdc or 0-10 Vdc	N/A	N/A
Full Range	(-0.5)-11 Vdc	N/A	N/A
Absolute Max.	18 V (without damage)	N/A	N/A
Input Impedance	>990 kOhms	N/A	N/A
Required Max. Sink Current	0.002 mA	N/A	N/A

Current Set Point Input Specifications

Nominal Range	4-20 mA or 0-20 mA	N/A	N/A
Full Range	0-22 mA	N/A	N/A
Absolute Max.	24 mA (without damage)	N/A	N/A
Input Impedance	100 Ohms	N/A	N/A

Flow Output (Voltage) Specifications

Nominal Range	0-5 Vdc, 1-5 Vdc or 0-10 Vdc	N/A	N/A
Full Range	(-1)-11 Vdc	N/A	N/A
Min Load Resistance	2 kOhms	N/A	N/A

Flow Output (Current) Specifications

Nominal Range	0-20 mA or 4-20 mA	N/A	N/A
Full Range	0-22 mA (@ 0-20 mA); 3.8-22 mA (@ 4-20 mA)	N/A	N/A
Max. Load	380 Ohms (for supply voltage: < 16 Vdc)	N/A	N/A

Analog I/O Alarm Output*

Type	Open Collector	N/A	N/A
Max. Closed (On) Current	25 mA	N/A	N/A
Max. Open (Off) Leakage	1µA	N/A	N/A
Max. Open (Off) Voltage	30 Vdc	N/A	N/A

Analog I/O Valve Override Signal Specifications**

Floating/Unconnected	Instrument controls valve to command set point	N/A	N/A
VOR < 0.3 Vdc	Valve Closed	N/A	N/A
1 Vdc < VOR < 4 Vdc	Valve Normal	N/A	N/A
VOR > 4.8 Vdc	Valve Open	N/A	N/A
Input Impedance	800 kOhms	N/A	N/A
Absolute Max. Input	(-25 Vdc) < VOR < 25 Vdc (without damage)	N/A	N/A

*The Alarm Output is an open collector or "contact type" that is CLOSED (on) whenever an alarm is active.

The Alarm Output may be set to indicate any one of various alarm conditions.

** The Valve Override Signal (VOR) is implemented as an analog input which measures the voltage at the input and controls the valve based upon the measured reading as shown in this section.

Product Dimensions

SLAMf50, Analog/RS485

MM/1 INCH

CABLE CONNECTOR	"W" DIMENSION
CABLE GLAND 0.20 [5.1] TO 0.39 [9.9] DIA.	28.6 [1.12]
CABLE 1/2" NPT-F CONDUIT	16.5 [0.65]
M20x1.5 (F) CONDUIT	12.5 [0.49]

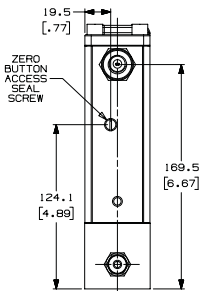

FITTING	"X" DIMENSION
1/8" TUBE COMP.	*180.7 [7.12]
1/4" TUBE COMP.	*185.3 [7.30]
3/8" TUBE COMP.	*188.4 [7.42]
1/2" TUBE COMP.	*192.4 [7.58]
1/4" VCR	181.8 [7.16]
1/4" VCO	173.6 [6.84]
1/4" NPT-F	176.2 [6.94]
6mm TUBE COMP.	*185.4 [7.30]
10mm TUBE COMP.	*188.8 [7.43]
3/8"-1/2" VCR	189.4 [7.46]
3/8"-1/2" VCO	184.8 [7.29]
1/4" RC-F (BSP)	174.2 [6.86]

* OVERALL LENGTH FINGER TIGHT

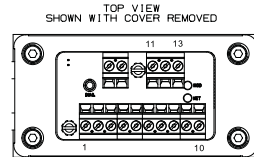
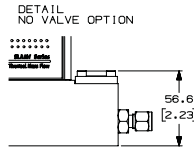
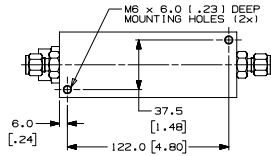
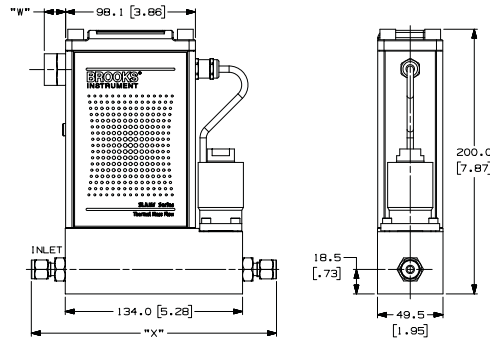
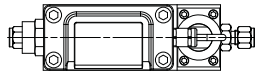

TERMINAL	FUNCTION
1	SETPOINT COMMON
2	FLOW OUTPUT (0-5V, 1-5V)
3	ALARM OUT
4	FLOW OUTPUT (0-20mA, 4-20mA)
5	POWER SUPPLY (13.5-27V)
6	SETPOINT INPUT (0-20mA, 4-20mA)
7	SETPOINT INPUT (0-5V, 1-5V)
8	POWER COMMON
9	FLOW OUT COMMON
10	VALVE OVERRIDE INPUT
11	AUX INPUT (0-5V, 0-10V)
12	RS-485, B (-), INPUT/OUTPUT
13	RS-485, A (+), INPUT/OUTPUT

Note: Aux Input is used for Remote Transducer Pressure Controllers only.

SLAMf60, Analog/RS485

MM/1 INCH

CABLE CONNECTOR	"W" DIMENSION
CABLE GLAND 0.20 [5.1] TO 0.39 [9.9] DIA.	28.6 [1.12]
CABLE 1/2" NPT-F CONDUIT	16.5 [0.65]
M20x1.5 (F) CONDUIT	12.5 [0.49]

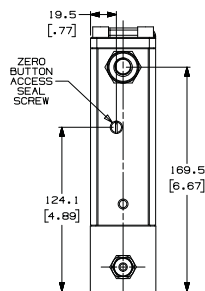

FITTING	"X" DIMENSION
1/8" TUBE COMP.	*145.3 [5.72]
1/4" TUBE COMP.	*149.9 [5.90]
3/8" TUBE COMP.	*152.9 [6.02]
1/2" TUBE COMP.	*157.0 [6.18]
1/4" VCR	146.3 [5.76]
1/4" VCO	138.2 [5.44]
1/4" NPT-F	140.7 [5.54]
6mm TUBE COMP.	*149.9 [5.90]
10mm TUBE COMP.	*153.2 [6.03]
3/8"-1/2" VCR	153.9 [6.06]
3/8"-1/2" VCO	149.4 [5.88]
1/4" RC-F (BSP)	138.8 [5.46]

* OVERALL LENGTH FINGER TIGHT

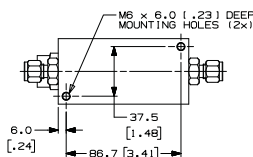
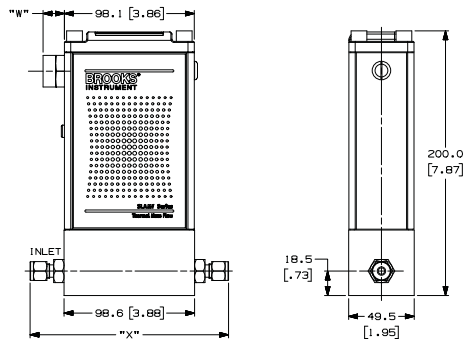
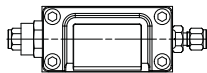

TOP VIEW
SHOWN WITH COVER REMOVED

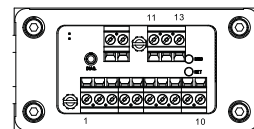

TERMINAL	FUNCTION
1	SETPOINT COMMON
2	FLOW OUTPUT (0-5V, 1-5V)
3	ALARM OUT
4	FLOW OUTPUT (0-20mA, 4-20mA)
5	POWER SUPPLY (13.5-27V)
6	SETPOINT INPUT (0-20mA, 4-20mA)
7	SETPOINT INPUT (0-5V, 1-5V)
8	POWER COMMON
9	FLOW OUT COMMON
10	VALVE OVERRIDE INPUT
11	AUX INPUT (0-5V, 0-10V)
12	RS-485, B (-), INPUT/OUTPUT
13	RS-485, A (+), INPUT/OUTPUT

Note: Aux Input is used for Remote Transducer Pressure Controllers only.

Product Dimensions (continued)

SLAMf51, DeviceNet

MM/1 INCH

CABLE CONNECTOR	"W" DIMENSION
CABLE GLAND 0.20 (5.1) TO 0.39 (9.9) DIA.	28.6 [1.12]
CABLE 1/2" NPT-F CONDUIT	16.5 [0.65]
M20x1.5 (F) CONDUIT	12.5 [0.49]

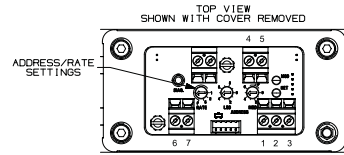
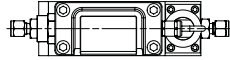

TERMINAL	FUNCTION
1	DRAIN
2	POWER SUPPLY (11-25V)
3	POWER COMMON
4	CAN_H
5	CAN_L
6	AUX COMMON
7	AUX INPUT (0-5V, 0-10V)

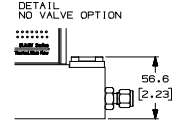
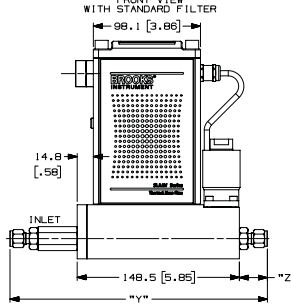
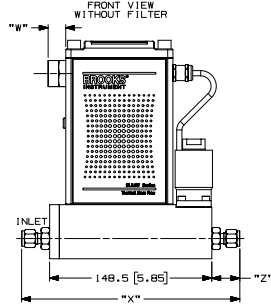
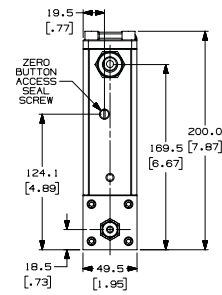

FITTING	"X" DIMENSION (Without Standard Filter)	"Y" DIMENSION (With Standard Filter)	"Z" DIMENSION
9/16"-19 UNF	148.5 [5.85]	184.5 [7.28]	N/A
1/4" TUBE COMP.	199.8 [7.87]	235.8 [9.28]	25.7 [1.01]
3/8" TUBE COMP.	202.9 [7.99]	238.8 [9.40]	27.2 [1.07]
1/2" TUBE COMP.	206.9 [8.15]	242.9 [9.56]	29.2 [1.15]
1/4" VCR	189.3 [7.45]	232.2 [9.14]	23.9 [0.94]
1/4" VCO	188.1 [7.41]	224.1 [8.82]	19.8 [0.78]
1/4" NPT	190.7 [7.51]	226.7 [8.92]	21.1 [0.83]
8mm TUBE COMP.	199.9 [7.87]	235.8 [9.28]	25.7 [1.01]
10mm TUBE COMP.	203.3 [8.00]	239.4 [9.42]	27.4 [1.08]
3/8"-1/2" VCR	203.9 [8.03]	239.9 [9.44]	27.7 [1.09]
3/8"-1/2" VCO	199.3 [7.85]	235.3 [9.26]	26.4 [1.00]
1/4" RC (BSP)	188.7 [7.43]	224.6 [8.84]	20.1 [0.79]

• OVERALL LENGTH FINGER TIGHT

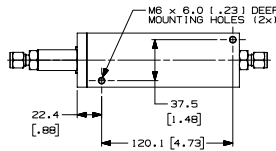

Note: Aux Input is used for Remote Transducer Pressure Controllers only.

SLAMf61, Analog/RS485

MM/1 INCH

CABLE CONNECTOR	"W" DIMENSION
CABLE GLAND 0.20 (5.1) TO 0.39 (9.9) DIA.	28.6 [1.12]
CABLE 1/2" NPT-F CONDUIT	16.5 [0.65]
M20x1.5 (F) CONDUIT	12.5 [0.49]

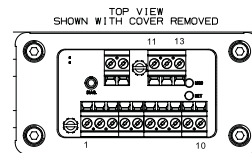
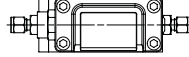

TERMINAL	FUNCTION
1	SETPOINT COMMON
2	FLOW OUTPUT (0-5V, 1-5V)
3	ALARM OUT
4	FLOW OUTPUT (0-20mA, 4-20mA)
5	POWER SUPPLY (13.5-27V)
6	SETPOINT INPUT (0-20mA, 4-20mA)
7	SETPOINT INPUT (0-5V, 1-5V)
8	POWER COMMON
9	FLOW OUT COMMON
10	VALVE OVERRIDE INPUT
11	AUX INPUT (0-5V, 0-10V)
12	RS-485, B (-), INPUT/OUTPUT
13	RS-485, A (+), INPUT/OUTPUT

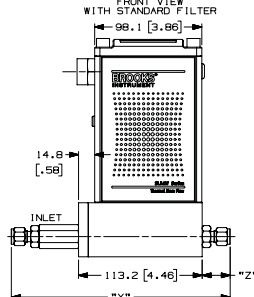
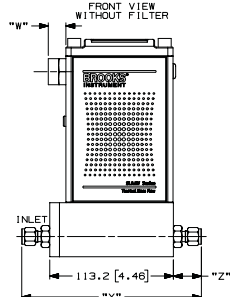
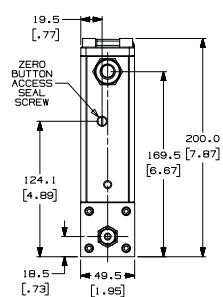

FITTING	"X" DIMENSION (Without Standard Filter)	"Y" DIMENSION (With Standard Filter)	"Z" DIMENSION
9/16"-18 UNF	113.2 [4.46]	149.2 [5.87]	N/A
1/4" TUBE COMP.	184.5 [6.48]	209.4 [8.24]	25.7 [1.01]
3/8" TUBE COMP.	187.7 [6.60]	212.5 [8.36]	27.2 [1.07]
1/2" TUBE COMP.	171.6 [6.76]	216.5 [8.52]	29.2 [1.15]
1/4" VCR	161.0 [6.34]	205.9 [8.10]	23.9 [0.94]
1/4" VCO	152.9 [6.02]	197.7 [7.78]	19.8 [0.78]
1/4" NPT	155.4 [6.12]	200.3 [7.89]	21.1 [0.83]
8mm TUBE COMP.	184.6 [6.48]	209.5 [8.25]	25.7 [1.01]
10mm TUBE COMP.	187.9 [6.61]	212.9 [8.38]	27.4 [1.08]
3/8"-1/2" VCR	188.7 [6.64]	213.5 [8.40]	27.7 [1.09]
3/8"-1/2" VCO	164.1 [6.46]	208.9 [8.22]	25.4 [1.00]
1/4" RC (BSP)	153.4 [6.04]	198.3 [7.81]	20.1 [0.79]

• OVERALL LENGTH FINGER TIGHT

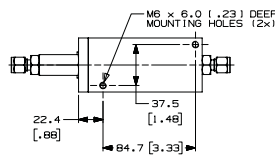

Note: Aux Input is used for Remote Transducer Pressure Controllers only.

Product Dimensions (continued)

SLAMf50 EtherCAT

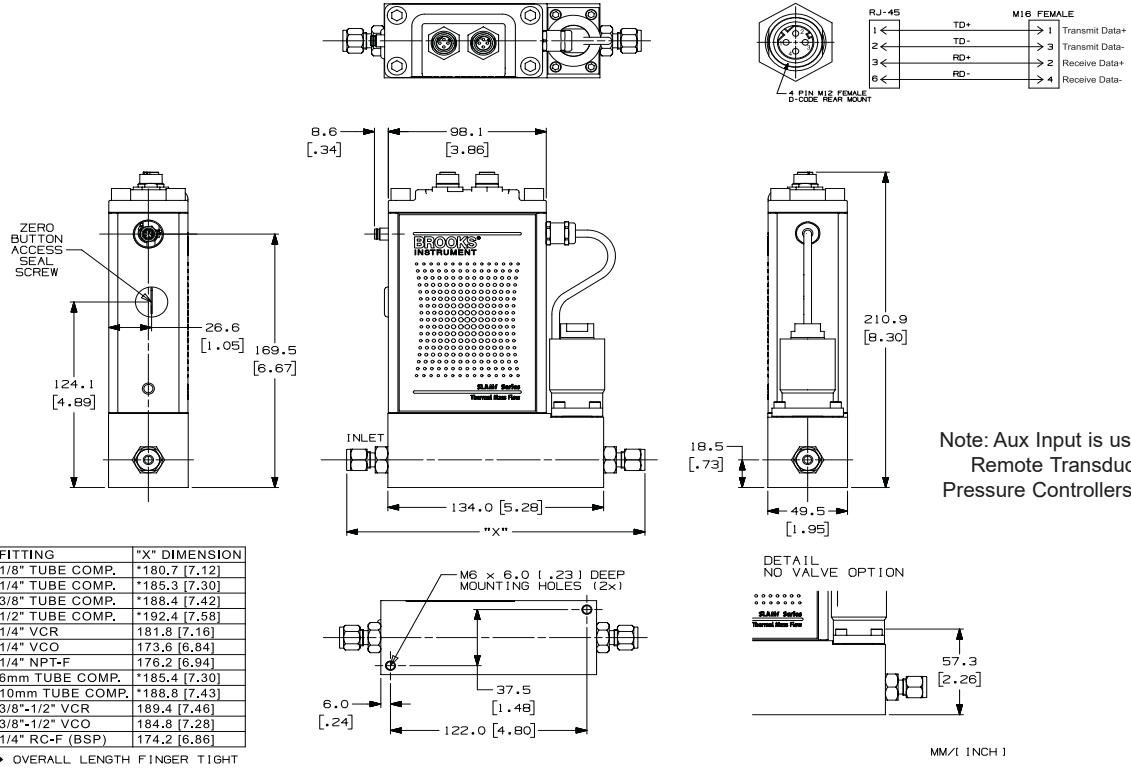

Note: Aux Input is used for Remote Transducer Pressure Controllers only.

SLAMf60, Profibus

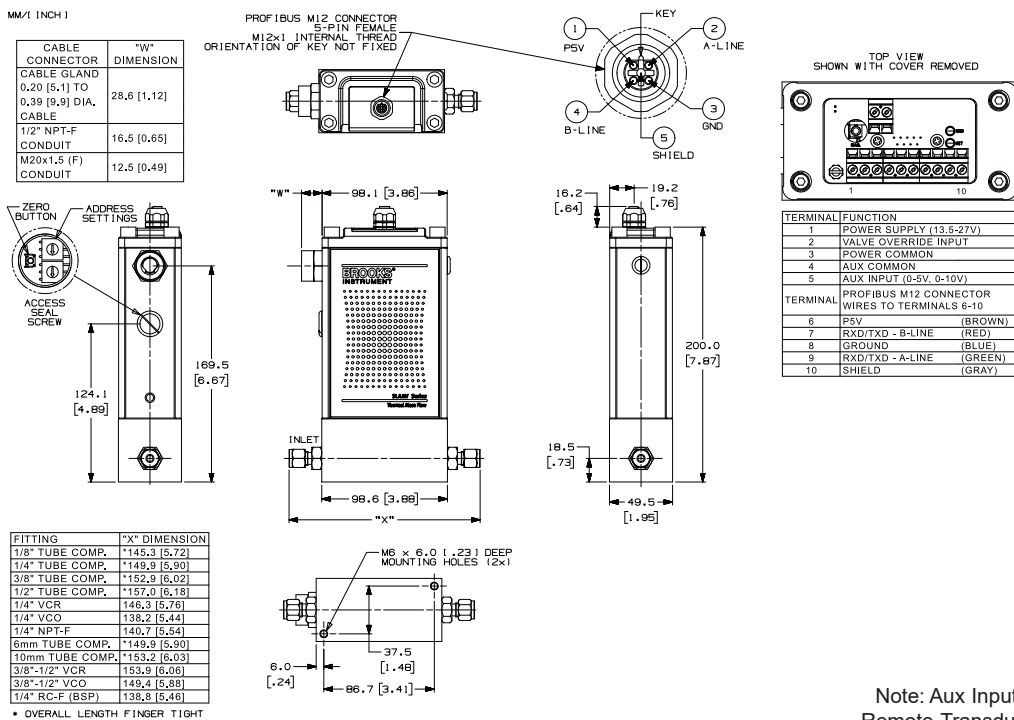

Note: Aux Input is used for Remote Transducer Pressure Controllers only.

Product Dimensions (continued)

SLAMf53, Profibus

MM/1 INCH

CABLE CONNECTOR	"W" DIMENSION
CABLE GLAND 0.20 [5.1] TO 0.39 [9.9] DIA.	28.6 [1.12]
CABLE 1/2" NPT-F CONDUIT	16.5 [0.65]
M20x1.5 (F) CONDUIT	12.5 [0.49]

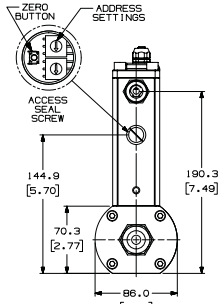

FITTINGS	"X" DIMENSION
9/16" - 18 UNF	235.4 [9.27]
1-1/16" - 12 UN	235.4 [9.27]
1-5/16" - 12 UN	235.4 [9.27]
1/2" NPT	235.4 [9.27]
1" NPT	235.4 [9.27]
1-1/2" NPT	235.4 [9.27]
1/2" RC (BSP)	235.4 [9.27]
1" RC (BSP)	235.4 [9.27]
3/8" TUBE COMP.	*290 [11.42]
1/2" TUBE COMP.	*304 [11.97]
3/4" TUBE COMP.	*304 [11.97]
1" TUBE COMP.	*311.7 [12.27]
1/2" VCO	286.3 [11.27]
3/4" VCO	293.9 [11.57]
1" VCO	296.4 [11.67]
1/2" VCR	293.9 [11.57]
3/4" VCR	318.7 [12.47]

• OVERALL LENGTH FINGER TIGHT

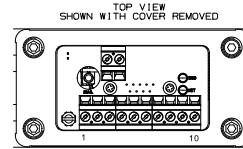
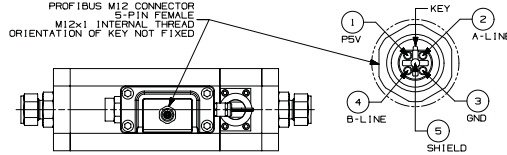

TERMINAL	FUNCTION
1	POWER SUPPLY (13.5-27V)
2	VALVE OVERRIDE INPUT
3	POWER COMMON
4	AUX COMMON
5	AUX INPUT (0-5V, 0-10V)
6	PSV (BROWN)
7	RXD/TXD - B-LINE (RED)
8	GROUND (BLUE)
9	RXD/TXD - A-LINE (GREEN)
10	SHIELD (GRAY)

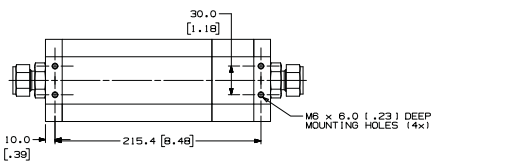
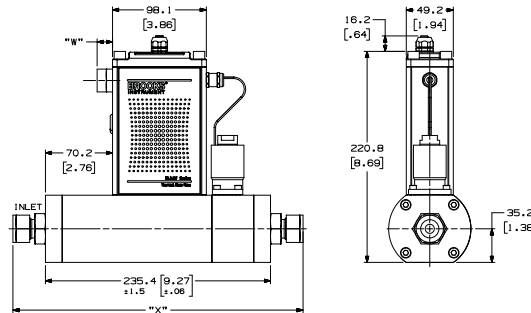

Note: Aux Input is used for Remote Transducer Pressure Controllers only.

SLAMf63, DeviceNet

MM/1 INCH

CABLE CONNECTOR	"W" DIMENSION
CABLE GLAND 0.20 [5.1] TO 0.39 [9.9] DIA.	28.6 [1.12]
CABLE 1/2" NPT-F CONDUIT	16.5 [0.65]
M20x1.5 (F) CONDUIT	12.5 [0.49]

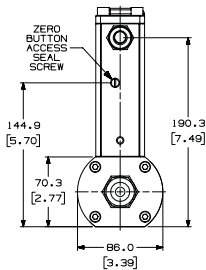

FITTINGS	"X" DIMENSION
9/16" - 18 UNF	191.6 [7.54]
1-1/16" - 12 UN	191.6 [7.54]
1-5/16" - 12 UN	191.6 [7.54]
1/2" NPT	191.6 [7.54]
1" NPT	191.6 [7.54]
1-1/2" NPT	191.6 [7.54]
1/2" RC (BSP)	191.6 [7.54]
1" RC (BSP)	191.6 [7.54]
3/8" TUBE COMP.	*246.0 [9.69]
1/2" TUBE COMP.	*260.4 [10.25]
3/4" TUBE COMP.	*260.4 [10.25]
1" TUBE COMP.	*268.0 [10.55]
1/2" VCO	242.6 [9.55]
3/4" VCO	250.2 [9.85]
1" VCO	252.7 [9.95]
1/2" VCR	250.2 [9.85]
3/4" VCR	273.1 [10.75]

• OVERALL LENGTH FINGER TIGHT

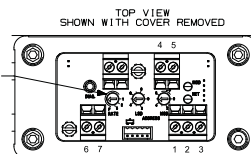
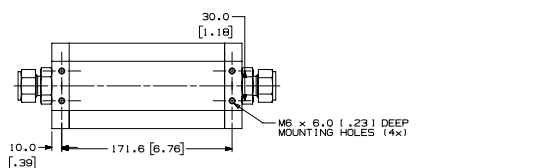
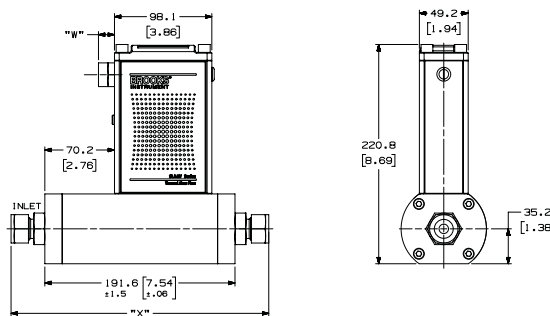
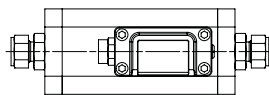

TERMINAL	FUNCTION
1	DRAIN
2	POWER SUPPLY (11-25V)
3	POWER COMMON
4	CAN_H
5	CAN_L
6	AUX COMMON
7	AUX INPUT (0-5V, 0-10V)

Note: Aux Input is used for Remote Transducer Pressure Controllers only.

Product Dimensions (continued)

SLAMf64, 1-1/2" or 2" FNPT, RS485

CABLE CONNECTOR	'D' DIMENSION
CABLE GLAND 0.20 [5.1] TO 0.39 [9.9] DIA. CABLE	28.6 [1.12]
1/2" NPT-F CONDUIT	16.5 [0.65]
M20x1.5 (F) CONDUIT	12.5 [0.49]

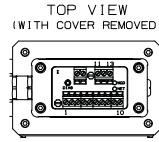
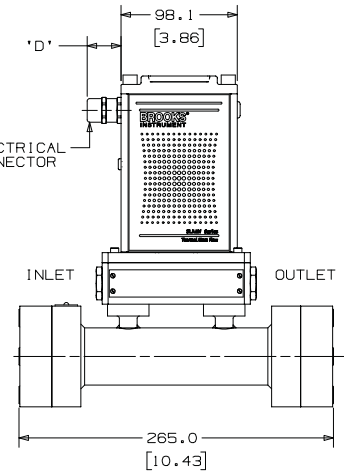
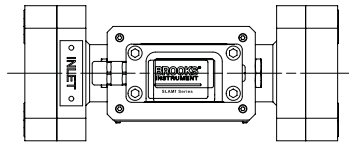
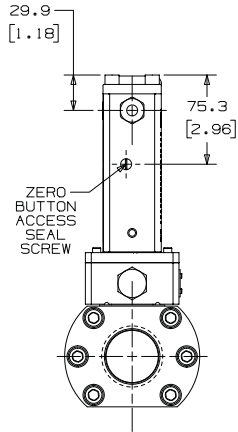

TERMINAL	FUNCTION
1	SETPOINT COMMON
2	FLOW OUTPUT (0-5V, 1-5V)
3	ALARM OUT
4	FLOW OUTPUT (0-20mA, 4-20mA)
5	POWER SUPPLY (13.5-27V)
6	SETPOINT INPUT (0-20mA, 4-20mA)
7	SETPOINT INPUT (0-5V, 1-5V)
8	POWER COMMON
9	FLOW OUT COMMON
10	VALVE OVERRIDE INPUT
11	AUX INPUT (0-5V, 0-10V)
12	RS-485, B (-), INPUT/OUTPUT
13	RS-485, A (+), INPUT/OUTPUT

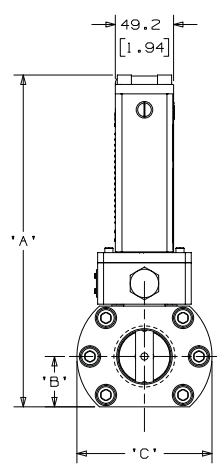

MECHANICAL CONN.	'A' DIMENSION	'B' DIMENSION	'C' DIMENSION
1-1/2" FNPT	280 [11.02]	42.5 [1.67]	114.0 [4.49]
2" FNPT	290 [11.42]	47.5 [1.87]	124.0 [4.88]

MM
(INCH)

Note: Aux Input is used for Remote Transducer Pressure Controllers only.

See Instruction Manual for additional configurations.

Certifications

Mark	Agency	Certification	Applicable Standard	Details
	UL (Recognized)	Class I, Div 2, Group A, B, C, D Class I, Zone 2, IIC T4 Class II, Zone 22 IP66	UL & CSA Standards	E73889 Vol 3, Sec 4
	UL (Listed)	Class I, Div 2, Group A, B, C, D Class I, Zone 2, IIC T4 Class II, Zone 22 IP66	UL & CSA Standards	E73889 Vol 1, Sec 25
	ATEX	II 3 G Ex nA IIC T4 Gc II 3 D Ex tc IIIC T 85 °C Dc IP66	EN 60079-0 : 2012 + A11 : 2013 EN 60079-15 : 2010 EN 60079-31 : 2014	KEMA 04ATEX1290 X
	IECEX*	Ex nA IIC T4 Gc Ex tc IIIC T 85 °C Dc IP66	IEC 60079-0 : 2011 + Corr. 2012 + Cor. 2013 IEC 60079-15 : 2010 IEC 60079-31 : 2013	IEC KEM 07.0043X
	KOSHA*	Ex nA IIC T4 Ex tD A22 IP66 T85°C	The Ministry of Employment and Labor Notice No. 2013-34 Article 34 of the Industrial Safety and Health	15-AV4BO-0638 15-AV4BO-0639 16-AV4BO-0328X 16-AV4BO-0327X
	CE	EMC Directive 2014/30/EU Directive 2011/65/EU	EN:61326-1:2013	EMC RoHS

*Not available on SLAMf64

Model Code

Code Description	Code Option	Option Description
I. Base Model Numbers	SLA	
II. Package / Finish Specifications	MF	Standard Elastomer Series
III. Function	5	Mass Flow Controller
	6	Mass Flow Meter
IV. Body Size	0	3 ccm - 50 lpm N ₂ Equivalent
	1	20 - 100 lpm N ₂ Equivalent
	3	100 - 2500 lpm N ₂ Equivalent
	4	300 - 36000 lpm N ₂ Equivalent
V. Digital I/O Communication	A	None (select applicable analog I/O)
	D	DeviceNet I/O (with 5-pin micro connector)
	E	EtherCAT
	J	DeviceNet I/O (with PG11 cable gland)
	K	DeviceNet I/O (with M20x1.5 conduit)
	L	DeviceNet I/O (with 1/2" NPT (F) conduit)
	P	Profibus (5-pin female M12, M20x1.5 conduit)
	R	Profibus (5-pin female M12, PG11 cable gland)
	T	Profibus (5-pin female M12, 1/2" NPT (F) conduit)
S	RS485 (select applicable analog I/O)	
VI. Mechanical Connection (Body size 0 & 1 only)	1A	Without adapters, 9/16" - 18 UNF
	1B	1/4" tube compression
	1C	1/8" tube compression
	1D	3/8" tube compression
	1E	1/4" VCR
	1F	1/4" VCO
	1G	1/4" NPT
	1H	6mm tube compression
	1J	10mm tube compression
	1L	3/8"-1/2" VCR
	1M	3/8"-1/2" VCO
	1P	1/2" tube compression
	1T	1/4" RC (BSP)
	1Y	3mm tube compression
	B1	1/4" tube compression w/Filter
	C1	1/8" tube compression w/Filter
	D1	3/8" tube compression w/Filter
	E1	1/4" VCR w/Filter
	F1	1/4" VCO w/Filter
	G1	1/4" NPT w/Filter
	H1	6mm tube compression w/Filter
	J1	10mm tube compression w/Filter
	L1	3/8"-1/2" VCR w/Filter
	M1	3/8"-1/2" VCO w/Filter
	P1	1/2" tube compression w/Filter
	T1	1/4" RC (BSP) w/Filter
	Y1	3mm tube compression w/Filter
VI. Mechanical Connection (Body size 3 unless noted Size 4 only. Size 4 noted)	2A	Without adapters, 9/16" - 18 UNF
	2B	1-1/16"-12 SAE/MS
	2C	3/8" tube compression
	2D	1/2" tube compression
	2E	3/4" tube compression
	2F	1" tube compression
	2G	1/2" NPT (F)
	2H	1" NPT (F)
	2J	1-1/2" NPT (F) (Size 3 & 4)
	2K	1/2" VCO
	2L	3/4" VCO
	2M	1/2" VCR
	2N	1/2" RC (BSP)
	2P	1" RC (BSP)
	2R	1-5/16"-12 SAE/MS
	2S	1" VCO
	2T	3/4" VCR
	2U	1" VCR
	2W	2" NPT Size 4 only
	2X	12 mm tube compression

Model Code continued on next page.

Model Code (continued)

Code Description	Code Option	Option Description		
VI. Mechanical Connection (cont.) (Body size 3 unless noted Size 4 only. Size 4 noted)	3A	DIN DN15 PN40 Flange		
	3B	DIN DN25 PN40 Flange		
	3C	DIN DN40 PN40 Flange		
	3D	DIN DN15 PN40 Flange		
	3E	ANSI 1/2" 150# RF Flange		
	3F	ANSI 1/2" 300# RF Flange		
	3G	ANSI 1" 150# RF Flange		
	3H	ANSI 1" 300# RF Flange		
	3J	ANSI 1-1/2" 150# RF Flange (Size 3 & 4)		
	3K	ANSI 1-1/2" 300# RF Flange		
	3L	ANSI 2" 150# RF Flange (Size 4 only)		
	3N	ANSI 3" 150# RF Flange (Size 4 only)		
	3P	ANSI 3-1/2" 300# RF Flange (Size 4 only)		
	3Q	ANSI 3" 600# RF Flange (Size 4 only)		
	3R	DIN DN80 PN40 Flange (Size 4 only)		
	3S	DIN DN80 PN64 Flange (Size 4 only)		
	3T	DIN DN80 PN100 Flange (Size 4 only)		
	4A	ANSI 4" 150# RF Flange (Size 4 only)		
	4B	ANSI 4" 300# RF Flange (Size 4 only)		
	4C	ANSI 4" 600# RF Flange (Size 4 only)		
	4D	DIN DN100 PN16 Flange (Size 4 only)		
	4E	DIN DN100 PN40 Flange (Size 4 only)		
	4F	DIN DN100 PN64 Flange (Size 4 only)		
	6A	ANSI 6" 150# RF Flange (Size 4 only)		
	6B	ANSI 6" 300# RF Flange (Size 4 only)		
	6C	ANSI 6" 600# RF Flange (Size 4 only)		
	6D	DIN DN150 PN16 Flange (Size 4 only)		
	6E	DIN DN150 PN40 Flange (Size 4 only)		
	6F	DIN DN150 PN64 Flange (Size 4 only)		
	8A	ANSI 8" 150# RF Flange (Size 4 only)		
8B	ANSI 8" 300# RF Flange (Size 4 only)			
8C	DIN DN200 PN10 Flange (Size 4 only)			
8D	DIN DN200 PN16 Flange (Size 4 only)			
8E	DIN DN200 PN25 Flange (Size 4 only)			
8F	DIN DN200 PN64 Flange (Size 4 only)			
VII. O-ring Material	A	Viton		
	B	Buna		
	C	PTFE		
	D	Kalrez		
	E	EPDM (Not available in Size 4)		
	J	FDA/USP Class VI - Viton (Not available in Size 4)		
	L	FDA/USP Class VI - EPDM (Not available in Size 4)		
VIII. Valve Seat	A	None (Sensor only)		
	B	Viton (for body size 3, diaphragm material = PTFE)		
	C	Buna (for body size 3, diaphragm material = PTFE)		
	D	Kalrez (for body size 3, diaphragm material = PTFE)		
	E	EPDM (for body size 3, diaphragm material = PTFE) (Not available in Size 4)		
	F	PTFE		
IX. Valve Type	0	None (Sensor only)		
	1	Normally closed		
	2	Normally closed (Pressure diff. >30 psig (2 bar))		
	3	Normally closed (Pressure diff. <30 psig (2 bar))		
	4	Normally closed - high pressure		
	5	Normally open		
X. Analog I/O Communications	A	None - Digital Communications only		
	E	4-20 mA	0-5 Volt	PG11 Cable Gland
	F	0-5 Volt	0-5 Volt	PG11 Cable Gland
	G	4-20 mA	4-20 mA	PG11 Cable Gland
	H	0-5 Volt	4-20 mA	PG11 Cable Gland
	I	0-5 Volt	0-20 mA	PG11 Cable Gland
	J	0-5 Volt	0-5 Volt	1/2" NPT (F) Conduit
	K	4-20 mA	4-20 mA	1/2" NPT (F) Conduit
	N	0-5 Volt	4-20 mA	M20x1.5 Conduit
	O	0-5 Volt	0-20 mA	M20x1.5 Conduit
	P	4-20 mA	0-5 Volt	M20x1.5 Conduit
Q	0-20 mA	0-5 Volt	M20x1.5 Conduit	

Model Code continued on next page.

Model Code (continued)

Code Description	Code Option	Option Description		
X. Analog I/O Communications (cont.)	R	1-5 Volt	1-5 Volt	PG11 Cable Gland
	S	0-20 mA	0-20 mA	PG11 Cable Gland
	T	1-5 Volt	1-5 Volt	1/2" NPT (F) Conduit
	U	0-20 mA	0-20 mA	1/2" NPT (F) Conduit
	V	0-5 Volt	0-5 Volt	M20x1.5 Conduit
	W	1-5 Volt	1-5 Volt	M20x1.5 Conduit
	X	0-20 mA	0-20 mA	M20x1.5 Conduit
	Y	4-20 mA	4-20 mA	M20x1.5 Conduit
	Z	0-20 mA	0-5 Volt	PG11 Cable Gland
	5	0-5 Volt	4-20 mA	1/2" NPT (F) Conduit
	6	0-5 Volt	0-20 mA	1/2" NPT (F) Conduit
	7	4-20 mA	0-5 Volt	1/2" NPT (F) Conduit
	8	0-20 mA	0-5 Volt	1/2" NPT (F) Conduit
XI. Power Supply Inputs	1	±15 Vdc		
	2	24 Vdc		
XII. Output Enhancements	A	Standard response		
XIII. Certification	1	Safe Area		
	2	For Zone 2 Atex		
	3	Div. 2 / Zone 2 UL Listed		
	4	Div. 2 / Zone 2 UL Recognized		
	5	Zone 2 IECEx		
	6	KOSHA		

Sample Standard Model Code

I	II	III	IV	V	VI	VII	VIII	IX	X	XI	XII	XIII
SLA	MF	4	0	S	1A	A	B	1	E	1	A	1

Brooks Service and Support

Brooks is committed to assuring all of our customers receive the ideal flow solution for their application, along with outstanding service and support to back it up. We operate first class repair facilities located around the world to provide rapid response and support. Each location utilizes primary standard calibration equipment to ensure accuracy and reliability for repairs and recalibration and is certified by our local Weights and Measures Authorities and traceable to the relevant International Standards. Visit www.BrooksInstrument.com to locate the service location nearest to you.

START-UP SERVICE AND IN-SITU CALIBRATION

Brooks Instrument can provide start-up service prior to operation when required. For some process applications, where ISO-9001 Quality Certification is important, it is mandatory to verify and/or (re)calibrate the products periodically. In many cases this service can be provided under in-situ conditions, and the results will be traceable to the relevant international quality standards.

SEMINARS AND TRAINING

Brooks Instrument can provide seminars and dedicated training to engineers, end users, and maintenance persons. Please contact your nearest sales representative for more details.

Due to Brooks Instrument's commitment to continuous improvement of our products, all specifications are subject to change without notice.

TRADEMARKS

Brooks Brooks Instrument, LLC
All other trademarks are the property of their respective owners.



Global Headquarters

Brooks Instrument
407 West Vine Street
Hatfield, PA
19440-0903 USA
Toll-Free (USA): 888-554-FLOW
T: 215-362-3500
F: 215-362-3745
BrooksAM@BrooksInstrument.com

A list of all Brooks Instrument locations and contact details can be found at www.BrooksInstrument.com